

LED Logo Lights for Airbus A320 Family

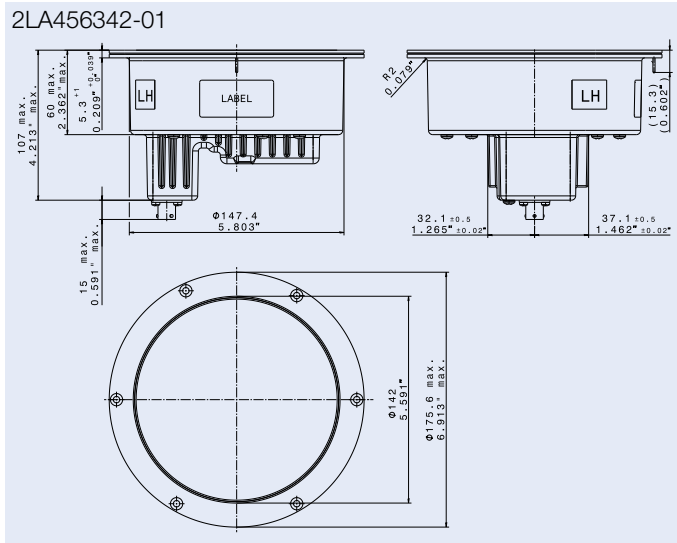

Where ingenuity takes off™

LED Logo Lights | 2LA456342-01/-02 for Airbus A320 Family



2LA456342-01 (LH)

These LED logo lights 2LA456342-01 (left) and -02 (right) are the ideal replacement option for current sealed beam units on the Airbus A320 family. UTC Aerospace Systems offers this new LED technology as an option to aircraft operators looking to reduce maintenance and operating costs over the life of the aircraft. The new LED lights have increased longevity and reliability as compared to the traditional sealed beam lights. The LED logo lights are integrated into the aircraft's horizontal stabilizer and optimally illuminate the airline's logo on the vertical stabilizer. They are mechanically and electronically fully interchangeable with the currently installed sealed beam units on the A320 series. Featuring a lifetime of approximately 20,000 operating hours, the new LED technology outperforms the reliability of the sealed beam unit by a factor of approximately 200.

Technical Data:

- Operating Voltage: 115 V_{rms}/360 to 800 Hz
- Operating Current: 200 mA_{rms} ± 100 mA_{rms}
- Peak Inrush Current: 4.2 A max (t < 100 ms)
- Nominal Frequency: 400 Hz
- Power Consumption: < 35 VA
- Power Factor: > 0.9
- Light Color: Aviation White 5,500 K+ correlated color temperature (CCT) in compliance with FAR § 25.1397
- Lifetime: approx. 20,000 operating hours
- Weight: 1.050 kg/2.315 lbs max.

Benefits and features:

- state-of-the-art LED technology
- standard on A320neo family aircraft, optional on currently built A320ceo family aircraft
- retrofit option for A320 family aircraft in operation: no aircraft modification required – fits into existing interface
- robust design with high vibration resistance
- better illumination performance in comparison to sealed beam unit
- low power consumption
- long lifetime
- high reliability
- EASA and FAA STC-versions as part numbers 1X2005097-01/-02 available on request

This document does not contain any export controlled technical data.

For additional information:

Goodrich Lighting Systems GmbH
 a UTC Aerospace Systems company
 Bertramstrasse 8
 59557 Lippstadt/Germany
 Tel.: +49 2941 7676 0
 Fax: +49 2941 7676 8432
 www.utcaerospacesystems.com